

# USERS' MANUAL FOR GAS BOILERS

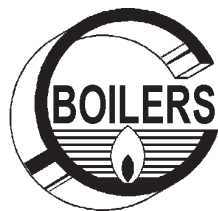

PLEASE READ THE MANUAL CAREFULLY: IT CONTAINS IMPORTANT INFORMATION REGARDING SAFETY, INSTALLATION, USE AND MAINTENANCE OF THE APPLIANCE

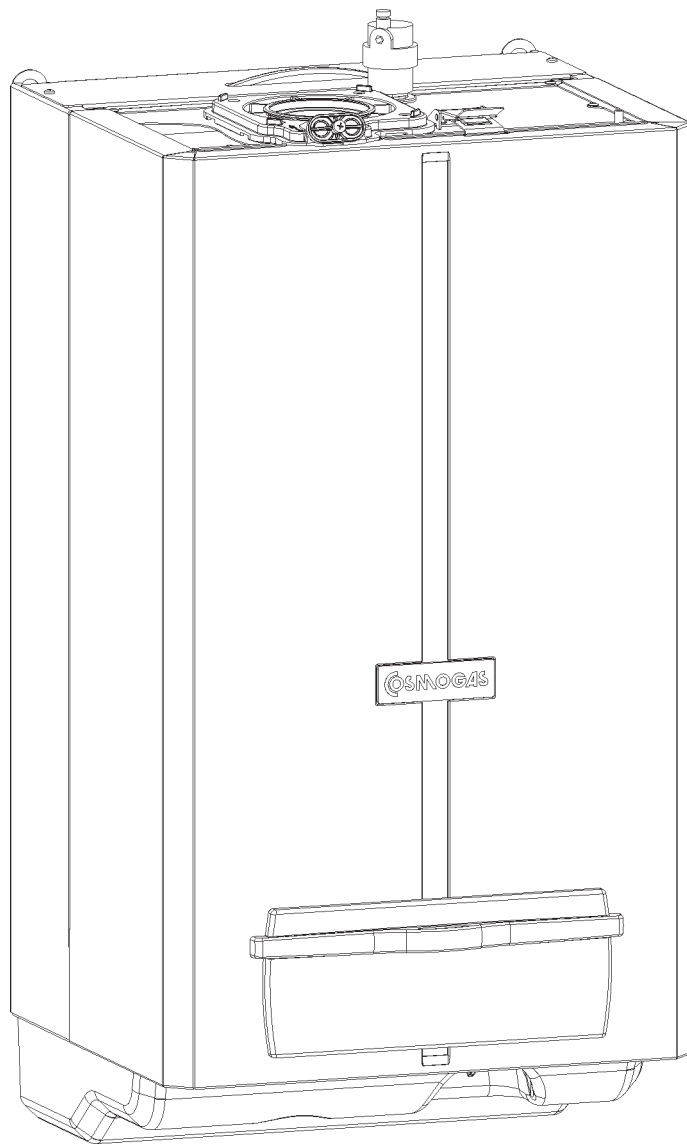

## MODELS:

- |                     |              |
|---------------------|--------------|
| <b>NOVADENS 24</b>  | <b>- 24B</b> |
| <b>NOVADENS 24C</b> | <b>- 24P</b> |
| <b>NOVADENS 34</b>  | <b>- 34B</b> |
| <b>NOVADENS 34C</b> | <b>- 34P</b> |
| <b>NOVADENS 45A</b> | <b>- 45C</b> |

# Table of contents

---

1 - GENERAL SAFETY WARNINGS .....	3
2 - GENERAL INFORMATION .....	4
2.1 - Introduction .....	4
2.2 - Description of models .....	4
2.3 - Manufacturer .....	4
2.4 - Key to symbols used .....	4
2.5 - Warranty .....	4
3 - USE .....	5
3.1 - Check that the cocks are open .....	5
3.2 - Check heating system pressure .....	5
3.3 - Overview .....	5
3.4 - Displays .....	6
3.5 - Start-up procedure .....	6
3.6 - "Users' menu" .....	6
3.7 - Summer mode .....	7
3.8 - Winter mode .....	7
3.9 - Adjusting the heating temperature .....	7
3.10 - Adjusting the heating temperature with climatic adjustment .....	7
3.11 - Domestic hot water temperature adjustment .....	8
3.12 - Room temperature adjustment .....	8
3.13 - Errors and alarms .....	8
3.14 - Pressure gauge .....	8
3.15 - Shutdown procedure .....	9
3.16 - Precautions against freezing .....	9
3.17 - Flue gas discharge .....	9
3.18 - Operating anomalies .....	9
3.19 - Remote control (on request) .....	10
4 - Warranty .....	11
4.1 - General warranty conditions .....	11
4.2 - Instructions for filling in the warranty card .....	11
4.3 - Warranty limits .....	11

# 1 - GENERAL SAFETY WARNINGS



## If you smell gas

- Close the gas cock.
- Ventilate the room.
- Do not use any electrical appliances, telephone included.
- Immediately call a qualified technician or the gas board from another room or building. If you cannot contact them, call the Fire Brigade.

## If you smell product of the combustion

- Switch off the appliance.
- Ventilate the room.
- Call a qualified technician.

## In the presence of water leaks

- Switch off the appliance.
- Close the central water mains cock.
- Call a qualified technician.

## Explosive or easily inflammable products

Do not store or use explosive or easily inflammable materials such as paper, solvents, paints, etc..., in the same room as the boiler.

## In the event of a breakdown

In the event of breakdown and/or malfunctioning of the appliance, disconnect it, do not attempt to repair it or intervene in any way whatsoever. Contact a qualified technician.

## Qualified technicians

Qualified technicians are personnel with specific, technical training in the heating system component sector and with regards to domestic hot water production for public use, fuel gas systems and electrical systems. These individuals must have the legally required qualifications.

- ☞ This booklet forms an integral and essential part of the product and must be carefully kept by the user, for any future consultation. Ensure that this booklet is handed over to the new owners and/or installer if the appliance should change hands or be moved for any reason whatsoever.
- ☞ The installation, setting and modification of the gas appliance must be carried out by qualified technicians, in compliance with local and national norms and the instructions in the installation and maintenance manual.
- ☞ Flue pipes must not be modified in any way.
- ☞ The user, in accordance with these instructions, must keep the appliance in satisfactory running order and ensure reliable, safe operating.
- ☞ The user is responsible for employing a qualified technician to carry out maintenance work on the appliance in compliance with local and national norms and the matters stated in the installation and maintenance manual. We highly recommend arranging a regular maintenance contract with a qualified technician.
- ☞ The manufacturer cannot be held responsible for any damage to people, animals or property caused by inadequate maintenance.
- ☞ Do not obstruct the ends of the venting pipes .
- ☞ The technician will explain the functioning, use of the appliance and use of the system to the user.
- ☞ The user must be familiar with filling and discharge procedures for the boiler, and the control and eventual adjustment of water pressure in the heating circuit.
- ☞ The user must be familiar with the procedures for fully optimizing the conservation of energy and avoiding waste of the entire heating system.
- ☞ Regularly check the system pressure using the pressure gauge "13" (see figure 1) to ensure a reading between 1 and 1.5 bar.
- ☞ Wait a few minutes after opening the gas supply cock before starting the boiler up.
- ☞ Do not leave the boiler switched on unnecessarily if it is not going to be used for long periods; in such situations, close the gas cock and disconnect from the electricity mains supply. Consult section 3.16 if there is a risk of freezing.
- ☞ Do not touch the flue gas discharge pipe, during and for some time after operations, as it is very hot.

## 2 - GENERAL INFORMATION

### 2.1 - Introduction

Congratulations!

You have effectively purchased one of the best products on the market. Each single part is built, tested and assembled, with pride, at the COSMOGAS factories, thereby guaranteeing optimum quality control.

Thanks to on-going research carried out by COSMOGAS, this product has been conceived and is considered to be the best in its class with regards to respect for

the environment, since it falls within class 5 (less polluting) envisaged by technical norm EN 297 (and EN 483) and has an elevated efficiency, 4 stars as per EC Directive 92/42/EEC. Great importance is also given to the end of the appliance's useful life. All its components can easily be separated into similar and completely recyclable parts.

### 2.2 - Description of models

NOVADENS XXYYYY

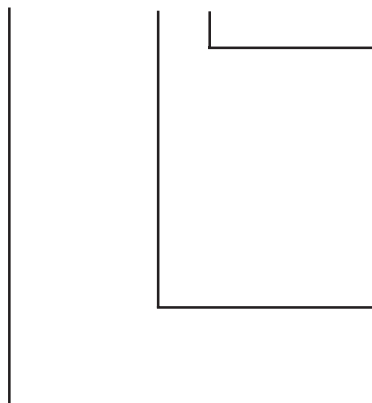

“ ” = Boiler with exchanger sanitary to partial accumulation;  
“A” = Boiler for only heating without integrated pump;  
“B” = Boiler which can be combined with BWR C series storage tank;  
“C” = Boiler for only heating with integrated pump;  
“P” = Boiler with exchanger secondary for D.H.W., to plates;  
“0834” = Boiler for low temperature central heating systems.

24 = Boiler with maximum input heat of 25 kW  
34 = Boiler with maximum input heat of 34.8 kW

Gas-fired, condensing, hot water boiler, with sealed combustion chamber and pre-mix burner, for heating and domestic hot water production.

### 2.3 - Manufacturer

COSMOGAS srl  
Via L. da Vinci 16  
47014 - Meldola (FC) ITALY  
Tel. +39 0543 498383  
Fax. +39 0543 498393  
www.cosmogas.com  
info@cosmogas.com

### 2.4 - Key to symbols used



**General danger!**

Failure to observe this warning may compromise the smooth running of the appliance or cause serious damage to individuals, animals or property.

● Operation symbol

☞ Important indication symbol

### 2.5 - Warranty

See section 4

## 3 - USE

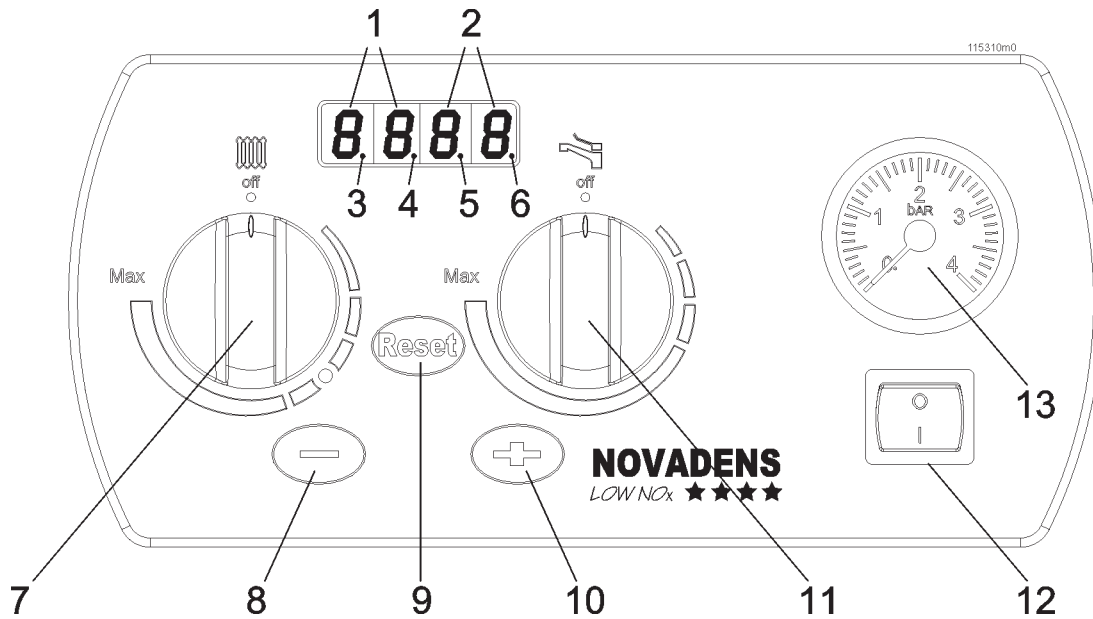

- 1 - Parameter display.
- 2 - Display of values adopted by parameters.
- 3 - Burner status indicator. On = burner on, flashing = burner off.
- 4 - Domestic hot water service status indicator. On = d.h.w. on, Off = d.h.w. off.
- 5 - Indicator of decimal of value displayed.
- 6 - Heating service status indicator. On = heating on, Off = heating off.
- 7 - Heating temperature and start control.
- 8 - Key for decreasing parameter values.
- 9 - Key for resetting shutdowns and for scrolling the list of parameters.
- 10 - Key for increasing parameter values.
- 11 - Domestic hot water temperature and start control.
- 12 - On/off power switch.
- 13 - Heating circuit pressure gauge.

Figure 1 - Instrument panel

### 3.1 - Check that the cocks are open

- The gas cock must be open;
- any supply and return valves must be open;
- any hot and cold water valves must be open.

### 3.2 - Check heating system pressure

If the pressure inside the heating circuit falls below 0.5 bar, the appliance switches off and the display 1 as per

figure 1, shows **FILL** to indicate that it is necessary to restore the correct pressure. Proceed as follows:

- open the filling cock (see figure 5) turning it in a counter-clockwise direction;
- check the pressure on the pressure gauge "13" of figure 1, it must reach a pressure of 1.5 bar and the indication

**FILL** must disappear;  
 ● close the filling cock (see figure 5) turning it in a clockwise direction.

**CAUTION!!!** During normal operations, the filling cock (see figure 5) must always remain in the closed position.

If, with time, the pressure drops, restore the correct value. This operation may have to be repeated several times during the first month of operations to remove any gas bubbles present.

### 3.3 - Overview

The boiler is pre-set with standard parameters. However, it is possible to make a number of changes or consult the parameters by means of using the "Users' Menu" (see section 3.6). During functioning display "1" of figure 1 displays the status of the boiler and display "2" (see figure 1) shows the

value of the parameter. The various operating statuses are shown in the table in figure 2.

Within the "Users' Menu" (see section 3.6) it is possible to check the last lock-outs or errors which have occurred. In addition to the operating modes, the instrument panel provides important information on the current functioning of the boiler, via the indicators "3", "4", "5" and "6" of figure 1. In particular:

- the indicator "3" displays whether the burner is functioning (on) or whether it is off (blinking);
- the indicator "4" displays whether the domestic hot water service is on or off;
- the indicator "6" displays whether a heating service request is active (on) or nor (off).

# 3 - USE

## POSSIBLE DISPLAYS

PARAMETER	DESCRIPTION	ON DISPLAY "2" (figure 1)
<b>O</b>	Boiler on stand-by or on hold (no heating or hot water request exists)	Boiler temperature (°C)
<b>P</b>	Anti-freeze function active	Boiler temperature (°C)
<b>A</b>	Caution!!! Domestic hot water active for more than 120 minutes (turn domestic hot water to OFF position in order to reinstate heating). Check that there are no leaking taps. If the problem persists, contact a professionally qualified technician	Boiler temperature (°C)
<b>FILL</b>	Caution!!! System pressure too low, fill system follow section 3.2.	No display
<b>d</b>	Domestic hot water service on	Domestic hot water temperature (°C)
<b>C</b>	Heating service on	Heating temperature (°C)
<b>L</b>	Boiler in lock-out mode. To reset it, press the <b>Reset</b> button. If the lock-out occurs frequently, contact a professionally qualified technician.	Lock-out code (see installation and maintenance manual)
<b>E</b>	Boiler fault. Contact a professionally qualified technician	Error code (see installation and maintenance manual)
<b>F</b>	Auto-purging procedure in progress . It will end within 2 minutes	Boiler temperature (°C)

Figura 2 - Parameters displayed during functioning

### 3.4 - Displays

During normal operations, the parameters' display "1" and the values' display "2" (see figure 1) remain permanently on (if the "Energy Saving" mode has not be activated).

The parameters which can be displayed are shown with their meaning in the table shown in figure 2.

### 3.5 - Start-up procedure

- Open the gas cock;
- switch on electric power to the boiler;
- If the display shows code **E** 21, it means that the polarity has not been observed between phase and neutral;
- on initial start-up, the appliance carries out an auto-purging cycle lasting two minutes. This is indicated by the appearance of **F** on the display;
- wait two minutes until the end of the auto-purging cycle;
- turn knob "7" of figure 1 until it reaches the heating temperature desired. Turn knob "11" of figure 1 until it reaches the domestic water temperature desired.

The flame control appliance will start-up the burner.

If the burner fails to ignite within 5 seconds, the boiler will automatically attempt ignition another three times, after which if it fails to start-up, it will shut down and the display will show **L** 01.

Press the **Reset** button in order to re-set normal operating conditions. The boiler will automatically attempt another start-up.



**CAUTION!!! If the appliance frequently shuts down, contact a qualified technician to restore normal running conditions.**

Now the boiler will continue to operate in relation to the service requested and will indicate the following on display "1":

- d** if a domestic water request is active;
- C** if a heating request is active;
- O** if there is no domestic water or heating request active.

### 3.6 - "Users' menu"

Entry into the "Users' Menu" is shown by display "1" blinking. In order to access

the "Users' menu" just:

- press the **Reset** button for 2 seconds until the display starts to blink;
- press and release the **Reset** button several times until the parameter desired is displayed;
- by means of the **+** or **-** keys, it is possible to change the value of the parameter;
- press **Reset** in order to confirm the amended data and pass onto the next parameter;
- Once you have reached the end of the menu, on the last **Reset**, the display "1" stops blinking indicating exit from the "Users' menu".

If no key is pressed for more than 60 seconds, one automatically exists the menu. Any change in the parameters not confirmed using the **Reset** button, will be lost.

In this menu it is possible to consult and/or change the parameters indicated in figure 3.

## 3 - USE

### “USERS’ MENU”









PARAMETER	DESCRIPTION	INFORMATION ON DISPLAY “2”
	Adjustment of the gradient of the line as per figure 4. Visible only with climatic adjustment active. (See installation and instruction manual).	Setting range: 0.1-5.0
	Adjustment of “Minimum heating temperature”. Visible only with climatic adjustment active. (See installation and instruction manual).	Setting range: 20°C-60°C for radiant panels, 30°C - 60°C for radiators.
	Adjustment of “Maximum heating temperature”. Visible only with climatic adjustment active. (See installation and instruction manual).	Setting range: 45°C for radiant panels, 80°C for radiators.
	Adjustment of the parallelism “b” of the line as per figure 4. Visible only with climatic adjustment active. (See installation and instruction manual).	Only display. The regulation is carried out using the control “7” as per figure 1. It can adopt values ranging between -10°C and +10°C
	Display of calculated heating temperature (if climatic adjustment active) or display of temperature set via the control “7” as per figure 1.	Only display. It can adopt values ranging between 20°C and 80°C
	Display of domestic hot water temperature set via the control “11” as per figure 1.	Only display. It can adopt values ranging between 40°C and 70°C
	Display of last error registered.	Only display. It can adopt the values indicated in the installation and maintenance manual
	Display of last block which occurred.	Only display. It can adopt the values indicated in the installation and maintenance manual

Figure 3 - Parameters within the “Users’ Menu”

### 3.7 - Summer mode

To disable the heating functions for a prolonged period, leaving only the domestic hot water function, switch the heating temperature to minimum, until the wording OFF appears, by turning knob “7” of figure 1.

### 3.8 - Winter mode

In Winter mode, by means of the pump, the boiler sends the water to the system at the temperature set using knob “7” of figure 1.

When the temperature inside the boiler reaches the temperature set, the burner starts to modulate the flame so as to reduce the output to a minimum. If the temperature rises further, the burner shuts down.

Simultaneously, the pump which sends the water to the system is switched on and off by the room thermostat. This can be noted, because indicator “6” of figure 1 switches on and off in correspondence

with the on and off of the pump.

At first the pump may make a noise. This is due to the presence of residual air in the hydraulic system which will soon disappear on its own.

We recommend keeping the temperature set using knob “7” at the point shown by the symbols on the panel for a rational use of the boiler. If it is a particularly cold Winter and it is difficult to maintain the desired temperature, turn knob “7” to gradually higher values.

### 3.9 - Adjusting the heating temperature

To set the heating temperature, turn control knob “7” of figure 1. As soon as the knob is touched,  will blink on display and the temperature being set will appear on display “2”. As a rule, it is sufficient to turn control knob “7” to the half-way position. If it is a particularly cold Winter, progressively increase the temperature by rotating control “7”.

### 3.10 - Adjusting the heating temperature with climatic adjustment

The adjustment of the heating temperature, in the event that climatic adjustment has been set, is carried out by turning control “7” as per figure 1. As soon as the control is touched, display

“1” show a flashing  and display “2” shows the value in °C of translation on a parallel with the adjustment curve (see figure 4, detail “b”). As a rule, it is sufficient to adjust control “7” to the half-way position. If the Winter is particularly rigid, progressively increase the temperature using control “7” until the temperature inside the rooms is satisfactory. If the comfort produced by the climatic adjustment is not satisfactory (too hot, too cold, room temperature not constant)

# 3 - USE

just enter the users' menu and adjust the parameters corresponding to figure 4. It is necessary to consider that the thermal inertia of a dwelling is extremely high, therefore each time you make a change, wait at least 24 hours to see the result.

## 3.11 - Domestic hot water temperature adjustment

To adjust the domestic hot water, turn control knob "11" of figure 1. As soon as the knob is touched, **d** will blink on display "1" and the temperature being set will appear on display "2". It is advisable to set this value at 50°C-55°C; if a storage tank is present, the temperature can arrive at 60°C-65°C.

## 3.12 - Room temperature adjustment

It is necessary to install a time-programmable thermostat for an optimum setting of the room temperature and thus satisfactory energy saving; this is a device capable of switching on and off and/

or raising and lowering the room temperature, in relation to certain set times. Contact a qualified technician for the installation of this device.

This boiler is suitable for being connected to devices of this type.

## 3.13 - Errors and alarms

The boiler control device carries out numerous checks.

When it detects a malfunction, it shuts down the appliance and displays the reason for the shut down on the display. The boiler may stop as a result of two different series of shutdowns:

**L** and **E** followed by the number identifying the shutdown.

The shutdowns identified by **L** can be re-set by pressing **(Reset)**. If the boiler fails to re-start, or if it shuts down frequently, contact a qualified technician.

The shutdowns identified by **E** cannot be re-set unless the cause of the problem is eliminated. In such cases, it is necessary to contact a qualified

technician.

The alarms shown on the display by means of **A**, do not block the boiler, but

alert the user to the fact that a system anomaly is underway. E.g. domestic hot water cock leak.

In this event, if you wish to reinstate the heating function, you must turn control knob "11" to zero and eliminate the water leak.

## 3.14 - Pressure gauge

The pressure gauge (detail "13" of figure 1) is a device which indicates the pressure of the water within the heating circuit.

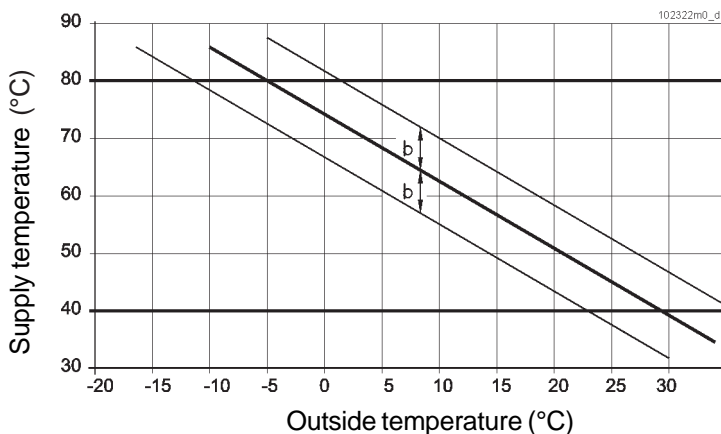
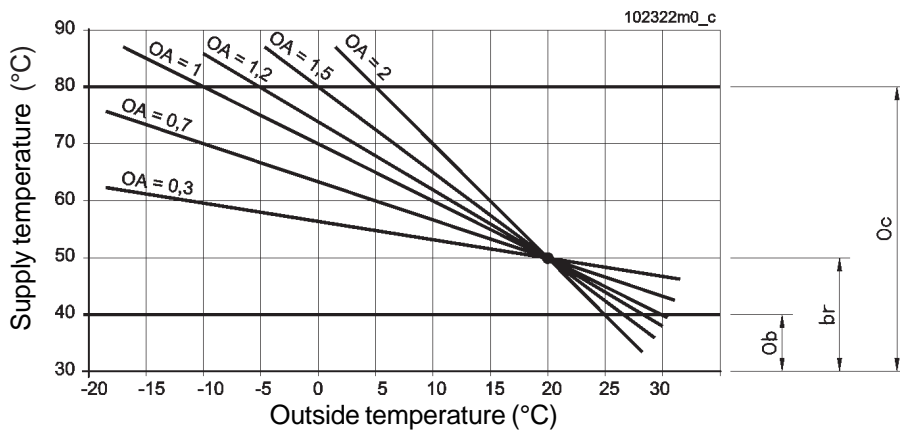

- OA** = Inclination of the line
- Ob** = Minimum heating temperature
- Oc** = Maximum heating temperature
- br** = "Fix point" of the angle fulcrum of the line
- b** = parallel shift of the line (possible using control "7" of figure 1)

Figure 4 - Graphs of the climatic adjustment for high temperature systems



## 3.15 - Shutdown procedure

If the boiler is to be shutdown for a relatively short time and there is no risk of freezing, simply disconnect from the mains the switch "12" of figure 1.

If there is a risk of freezing during your absence, leave the boiler connected to the mains and the gas open and carry out the procedure for the shutdown of the services, turning both knobs "7" and "11" of figure 1 to OFF.

Now the two services of the boiler are switched off. On reaching a boiler temperature of 7°C, the heating pump automatically switches on. If the temperature falls further to under 2°C, the burner will also switch on, so as to protect the system and the boiler itself from the effects of freezing weather conditions.

If the boiler is not used for a long period of time, we suggest emptying it. Contact a professionally qualified technician.

## 3.16 - Precautions against freezing

If you leave the dwelling, disconnect the gas and electricity supply, since the appliance is not protected against freezing. If it is switched off and runs the risk of being exposed to temperatures below zero, it is necessary to empty the appliance. Contact a professionally qualified technician.

**CAUTION!!!** It is absolutely forbidden to introduce chemical additives, such as anti-freeze or others, into the domestic water circuit.

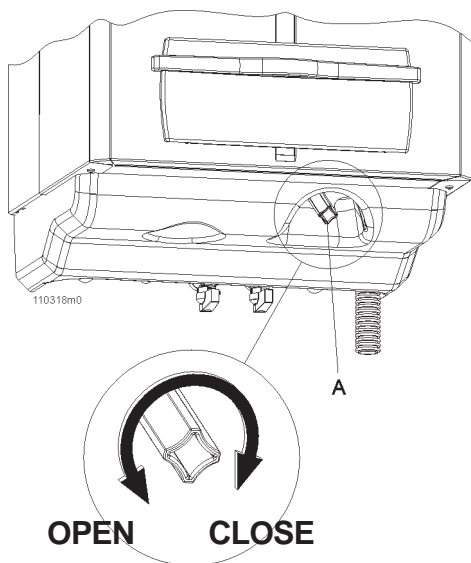

Figure 5 - Filling cock

## 3.18 - Operating anomalies

**If the boiler fails to start, check that:**

- ☞ The gas supply is open;
- ☞ the boiler power supply switch is on;
- ☞ the heating temperature control knob "7" is in the position suggested by the symbols;
- ☞ the boiler is not in lock-out mode.

Press the **Reset** button to re-start it;

- ☞ the room thermostat is set to a higher temperature than that of the room where it is installed and that it is programmed to call for heating at that time;

**If during winter operations, there is hot water but no heating, check that:**

- ☞ The room thermostat is set to a higher temperature than that of the room where it is installed and that it is programmed to call for heating at that time;
- ☞ any valves installed on the supply and return connections are open;
- ☞ open the radiator cocks to purge air;



**If after these checks, the system is still cold, do not attempt any repairs yourself but contact a qualified technician.**

## 3.17 - Flue gas discharge

Due to its high efficiency and low pollution levels, this boiler is considered to be ecological. Therefore, white smoke may be discharged from the discharge pipe, under specific atmospheric and operating conditions. There is no cause for alarm as it is only steam which condenses on contact with the outside cold air.

## 3.19 - Remote control (on request)

If the boiler is connected to the remote control, the heating temperature adjustment and domestic hot water temperature adjustment functions are performed directly on the remote control as indicated below:

- the adjustment of the heating is carried out directly using knob "A" as per figure 6;
- the adjustment of the domestic hot water is carried out directly using knob "C" as per figure 6.

Furthermore, it is possible to reset any alarms by pressing the RESET key (see figure, 6 detail "B").

Two indication lights are present on the remote control, and have the following meaning:

- green light on: heating service on and correct communication between boiler and remote control;
- green light blinking every 7 seconds: correct communication between boiler and remote control;
- red light on: boiler in lock-out status. It is possible to re-activate it by pressing the RESET key (see figure 6, detail "B"). If the lock-out occurs frequently, contact a professionally qualified technician;
- red light blinking: boiler in lock-out for more than 5 minutes. It is possible to re-activate it by pressing the RESET key (see figure 6, detail "B"). If the lock-out occurs frequently, contact a professionally qualified technician;
- green light and red light blinking: heating pressure anomaly (see section 3.2).

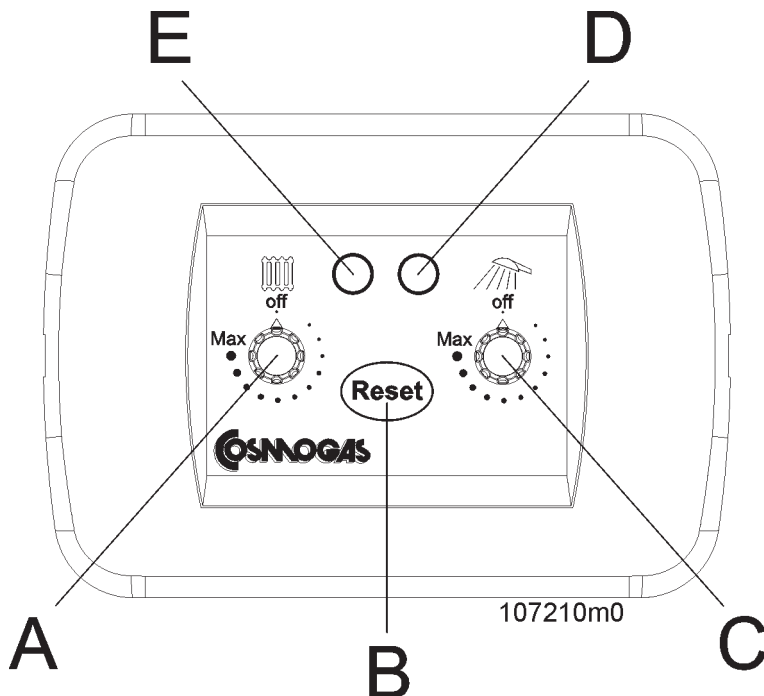

- A - Heating adjustment knob
- B - RESET key
- C - Domestic hot water adjustment knob
- D - Green light (for indications, see section 3.19)
- E - Red light (for indications, see section 3.19)

Figure 6 - Remote control

### 4.1 - General warranty conditions

**COSMOGAS** guarantees that all its products are free from manufacturing and material defects for **24** months from the testing and inspection date of the first start-up. Within the aforementioned period, **COSMOGAS** will repair or replace any manufactured parts found to be defective, excluding any defects caused by normal wear and tear during operations. Any transport and handling costs for replaced parts are at the customer's expense. The warranty does not cover compensation for any type of damage which may occur to people or property. The faulty materials replaced under warranty are the property of **COSMOGAS** and must be returned free of charge to our factory, within **30** days of their replacement, otherwise **COSMOGAS** will issue an invoice covering the cost of the replaced material.

All **COSMOGAS** products are subject to reserved ownership agreement until the purchased appliance has been fully paid for.

### 4.2 - Instructions for filling in the warranty card

- The installer must stamp the warranty certificate.
- Always request the intervention of one of our authorized technicians for the initial start-up and testing of the appliance; a list is enclosed with the instruction manual or can be found in the Yellow Pages under "Gas boilers".
- The technician will collect the warranty certificate and forward it to **COSMOGAS**.

### 4.3 - Warranty limits

The warranty is invalid:

- if the appliance is **not** installed by qualified technicians;
- if the appliance is not installed in compliance with **COSMOGAS** instructions and/or those established by national and/or local standards in force;
- the running and/or maintenance of the system is not carried out in compliance with these instructions and/or national and/or local standards in force;
- damage to the product has been caused by voltage fluctuations;
- damage to the product has been caused by the use of too hard, too acid or over oxygenated water;
- damage to the product has been caused by thermal shock, defective chimneys and/or flue gas discharge and air intake piping;
- the product has anomalies not dependent on **COSMOGAS**;
- the boiler has been tampered with due to adaptation work, repair work and replacement work using non-original parts;
- the repair work has been carried out by unauthorized personnel;
- the warranty certificate is not forwarded to **COSMOGAS** within **15** days of the date of **initial** start-up.

**COSMOGAS** cannot be held responsible for any accident, including those caused by the user, any compensation which does not concern boiler parts with recognized manufacturing defects being excluded. Court of competent jurisdiction: Forlì, ITALY.

# WARRANTY CERTIFICATE FOR "COSMOGAS" APPLIANCES

*Warranty valid 24 months*

---

---

## TO BE COMPLETED BY THE INSTALLER

The appliance has been installed by qualified technicians in possession of the legally required qualifications, in compliance with the instructions contained in this manual, on the installation and maintenance manual and follow national and/or local standards in force.

Date \_\_\_\_\_

Comments \_\_\_\_\_

INSTALLER (Stamp)

Signature \_\_\_\_\_

---

---

## TO BE COMPLETED BY THE SERVICE CENTRE

The appliance has been tested and inspected for initial start-up purposes by qualified technicians in possession of the legally required qualifications, in compliance with the instructions contained in this manual, on the installation and maintenance manual and follow national and/or local standards in force, with the following results:

POSITIVE  NEGATIVE

Date \_\_\_\_\_

Comments \_\_\_\_\_

SERVICE CENTRE (Stamp)

Service Centre signature

User signature

\_\_\_\_\_

\_\_\_\_\_









COSMOGAS s.r.l.  
Via L. da Vinci 16 - 47014  
MELDOLA (FC) ITALY  
info@cosmogas.com  
www.cosmogas.com